

# New Product Introduction

## Surround Neo & Ultra LED Highbay



## Applications

- Engineering Industry
- Power Industry
- Distillery Industry
- Jute Industry
- Steel Industry
- Cement Industry
- Warehouse



- Highbay luminaire having a standard efficacy of >110LPW(Surround Neo) & HP >125LPW(Surround Ultra)
- Integral surge protection of 4KV with additional 10KV external surge
- Superior heat dissipation
- Standard beam angle of 60 degree
- Ingress protection of IP 66
- Total harmonic distortion of <10%
- Available in 5700K CCT as std.
- Provided with 1 no 5 way 10 amps suitable for terminating max. 2.5 sq. mm incoming cable for faster installation
- Additional safety chain provided for flexible mounting

## Product code and ordering details

Product Code	Product Description	CCT	Approx Weight	Product Name
LI300417-A2	LHB11-80-CDL/60-M	5700K	2.9	Surround Neo
LI300425-A2	LHB11-100-CDL/60-M	5700K	3.7	Surround Neo
LI300435-A2	LHB11-120-CDL/60-M	5700K	3.7	Surround Neo
LI300440-A2	LHB11-140-CDL/60-M	5700K	3.7	Surround Neo
LI300445-A2	LHB11-150-CDL/60-M	5700K	3.7	Surround Neo

Product Code	Product Description	CCT	Approx Weight	Product Name
LI300419-A2	LHB11-80-CDL/60HPM	5700K	2.9	Surround Ultra
LI300426-A2	LHB11-100-CDL/60HPM	5700K	3.7	Surround Ultra
LI300436-A2	LHB11-120-CDL/60HPM	5700K	3.7	Surround Ultra
LI300441-A2	LHB11-140-CDL/60HPM	5700K	3.7	Surround Ultra
LI300446-A2	LHB11-150-CDL/60HPM	5700K	3.7	Surround Ultra

## Dimensional Details

**LHB11-80-CDL/60-M**  
**LHB11-80-CDL/60HPM**

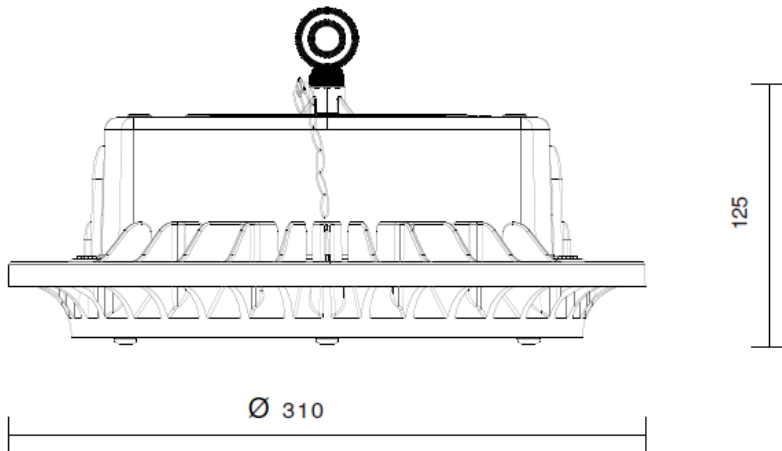
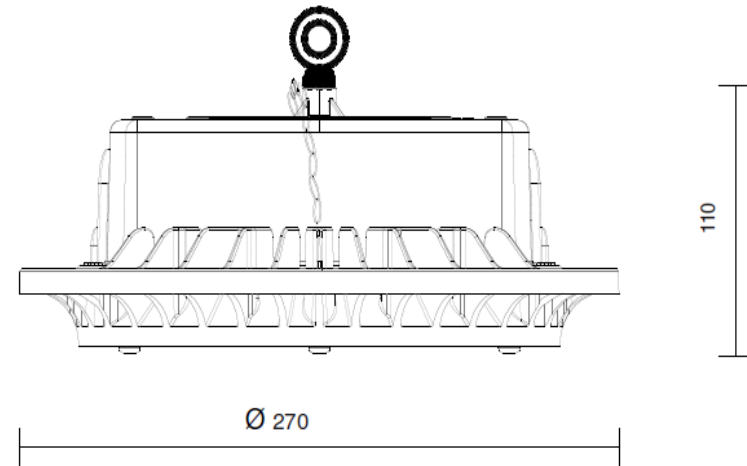

**LHB11-100-CDL/60-M**  
**LHB11-100-CDL/60HPM**  
**LHB11-120-CDL/60-M**  
**LHB11-120-CDL/60HPM**  
**LHB11-140-CDL/60-M**  
**LHB11-140-CDL/60HPM**  
**LHB11-150-CDL/60-M**  
**LHB11-150-CDL/60HPM**



## Polar Diagram

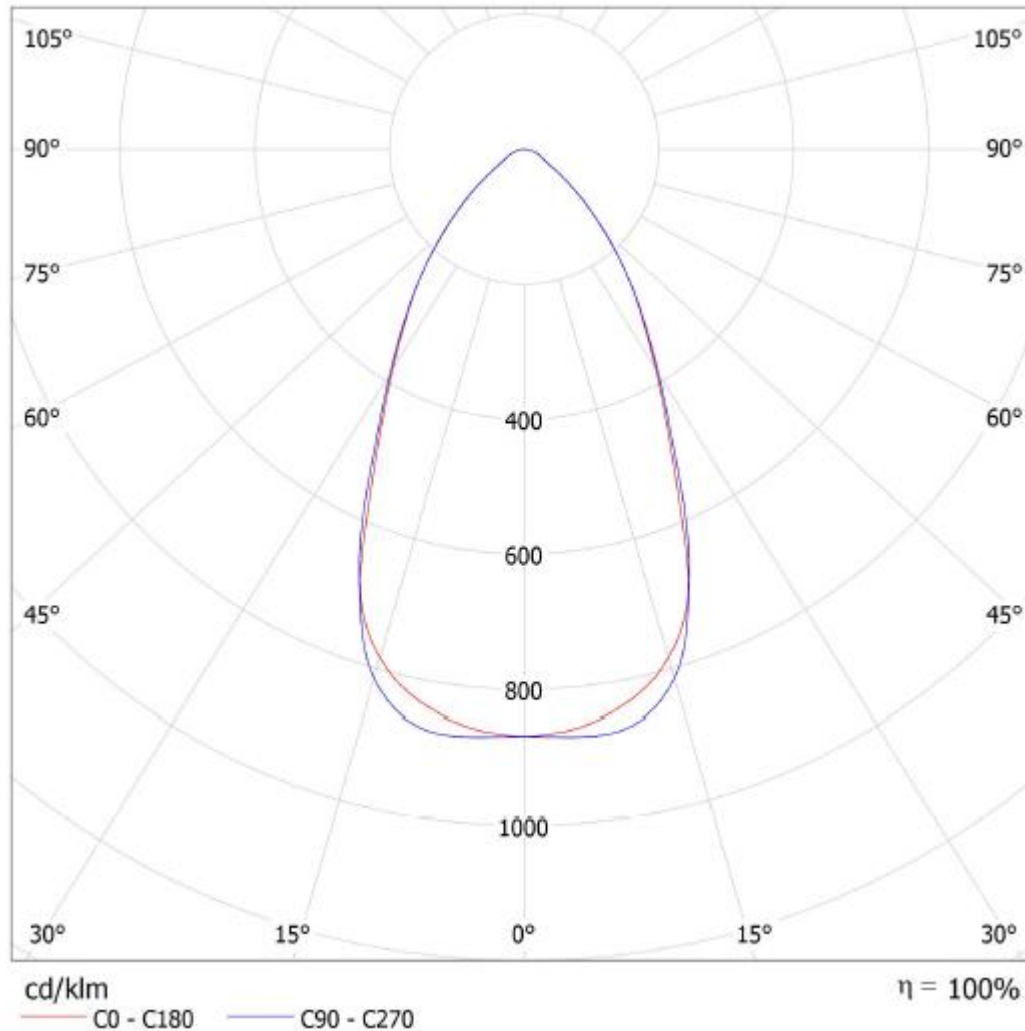

# Surround Neo & Ultra : LED Highbay

**Crompton**

## Standard Conformance

- Conforms to BIS standards
- Driver & LED conforms to ROHS guidelines
- Process of manufacturing is IS10322 complaint

